



Powerful Solutions

EagleEyes CCTV

SECURITY SOLUTIONS AND TECHNOLOGIES

LCD CCTV Monitor 20" 3D Filter & Deinterlace

- Newest High Performance **Deinterlace Chip** to improve Picture Quality
- **3D Comb Filter** to reduce Signal Noise
- NTSC/PAL Auto Detect
- Multi signal inputs supported - VGA (D-Sub), RCA (Composite Video) and **BNC Video-in Connectors**
- Adjustable height and turn
- Support VESA 100x100 wall mount kit 1+
- Support up to 1400 x 1050 SXGA High Resolution with Vivid Color
- Video Auto Adjust (VGA mode)
- High Contrast Ratio up to 1000:1, 5ms
- 2 watts Stereo Speakers with Amplifier included
- Low Power Consumption (40 watts max; stand-by mode 5 watts)
- 90~240 VAC 60/50 Hz Universal Power Supply
- High Performance and Long Lifetime Design

EE-LCD20-3D



Image With 3D Filter



Image Without 3D Filter

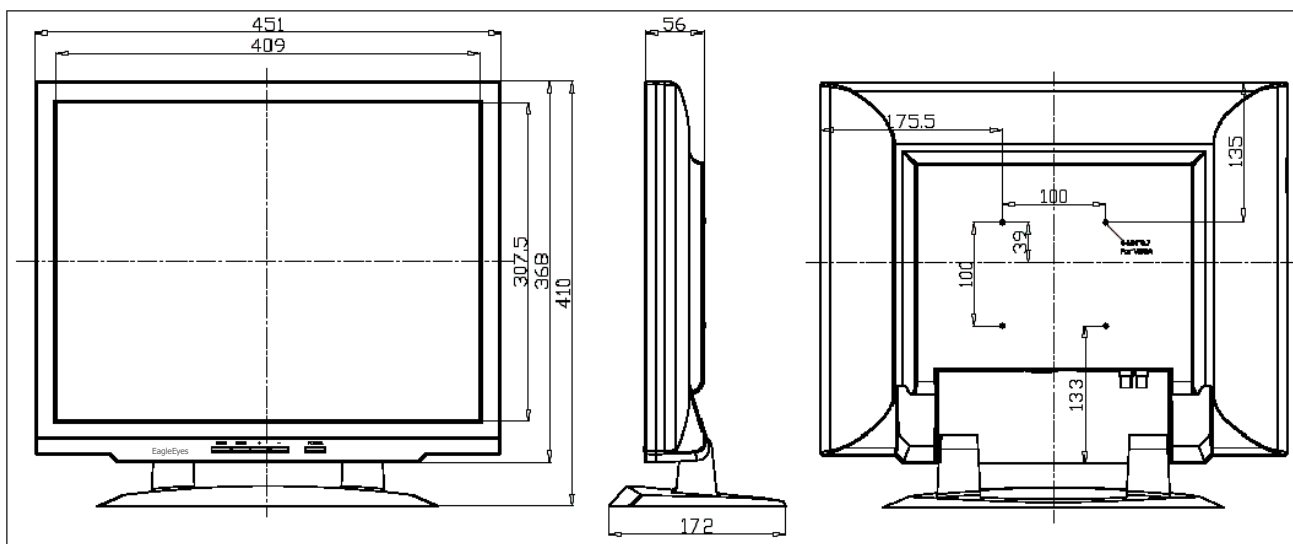

Av. República Argentina, 50 • 15º andar
 Curitiba PR 80240-210
 Tel: (041) 3342 1600 • Fax: (041) 3244 2200
 vendas@eaglevision.com.br • www.eaglevision.com.br





Powerful Solutions

EagleEyes CCTV

SECURITY SOLUTIONS AND TECHNOLOGIES

Technical Specification EE-LCD20-3D

Panel	Cell Type / Glass Surface	TFT LCD / Black Anti-Glare, low reflection coating	
	Aspect Ratio / Size	4 : 3 / 20.1" viewable diagonal area	
	Active Area / Pixel Pitch	408.24(H) x 306.18(V) mm / 0.2916(H) x 0.2916(V) mm	
	Native Resolution / Colors	1400(H) x 1050(V) / 16.7 Million	
	Brightness / Contrast	300 cd/m ² (typ) / 1000 : 1	
	Response Time	≤ 5 ms	
	Viewing Angle (typical)	H. 170° (- 85° ~ + 85°) , V. 160°(- 80° ~ + 80°)	
	Light Source	CCFL , Long life, 50,000 hrs (typ)	
Input Sources	Video System	NTSC / PAL / SECAM supported (Auto detecting)	
	PC System	Signal	Analog RGB (0.7/1.0 V _{p-p} , 75 ohms)
		Sync	Separate Sync, Composite Sync, Sync On Green
		Frequency	F _h : 30 - 82Khz , F _v : 50 -75Hz
Audio System	2W speaker x 2		
Input Terminals	1 x VGA (15 Pin Female D-Sub) , 1 x PC Audio (Stereo Headphone Jack) , 1 x DC Power Plug		
	1 x S-Video , 1 x CVBS (BNC) , 2 x Audio(RCA, Audio-R + Audio-L)		
Convenient Features	Auto Calibration , Back Light Adjustment , Plug&Play (VESA DDC/CI, DDC 2B)		
	OSD Multi-Languages , Wall Mount Ready (VESA 100 x 100 mm)		
Power	External AC-to-12VDC power adapter with universal / Auto-Sensing, AC 90 to 260V, 50 / 60 Hz		
Power Consumption	Operation / Power Saving	40 watt , < 5 watt (Support DPMS)	
Operating Condition	Temperature / Humidity	0°C ~ 50°C (32°F ~ 122°F) , 10% ~ 90% (no condensation)	
Storage Condition	Temperature / Humidity	- 20°C ~ 60°C (- 4°F ~ 140°F) , 10% ~ 90% (no condensation)	
Certification	FCC , CE		
Dimensions	Physical	With Base(W x H x D) : 451.0 x 408.9 x 172.0 mm	
		Without Base(W x H x D) : 451.0 x 368.0 x 57.0 mm	
	Carton	W x H x D = 560 x 463 x 205 mm	
Weight	N.W. / G.W.	6.7 Kgs / 7.7 Kgs	
Container Loaded	20ft / 40ft / 40ft HQ	TBD (Sets , By pallet)	
Options	Video / TV	Enhanced Panel	
	AV2	Panel with LED backlight	
	AV2-Looping	High brightness panel	
		Wide Temperature	
		Sun Light Readable	



Av. República Argentina, 50 • 15° andar
 Curitiba PR 80240-210
 Tel: (041) 3342 1600 • Fax: (041) 3244 2200
 vendas@eaglevision.com.br • www.eaglevision.com.br

