



Powerful Solutions

EagleEyes CCTV

SECURITY SOLUTIONS AND TECHNOLOGIES

LCD CCTV Monitor 15" 3D Filter Rackmount

- Newest High Performance **Deinterlace Chip** to improve Picture Quality
- **3D Comb Filter** to reduce Signal Noise
- NTSC/PAL Auto Detect
- Multi signal inputs supported - VGA (D-Sub), RCA (Composite Video) and **BNC Video-in Connectors**
- Rackmount Heavy Duty metal case
- Support VESA 75x75 wall mount kit 1+
- Support up to 1024 x 768 SXGA High Resolution with Vivid Color
- Video Auto Adjust (VGA mode)
- High Contrast Ratio up to 500:1
- 2 watts Stereo Speakers with Amplifier included
- Low Power Consumption (20 watts max; stand-by mode 2 watts)
- 90~240 VAC 60/50 Hz Universal Power Supply
- High Performance and Long Lifetime Design

EE-LCD15-3D-RK



Image With 3D Filter



Image Without 3D Filter

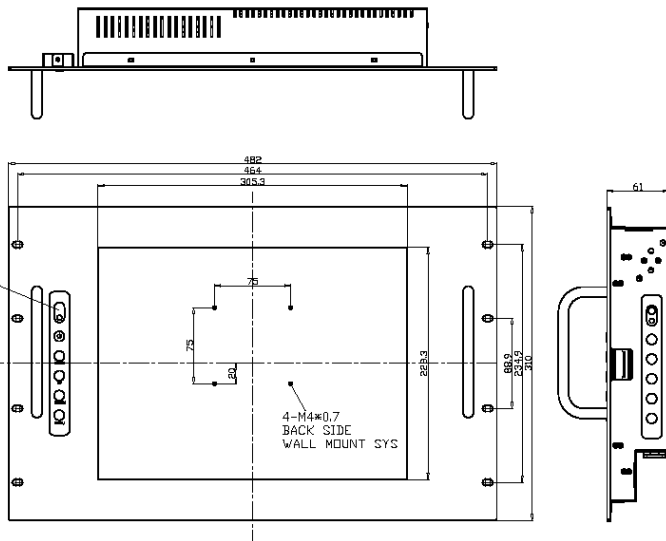

Av. República Argentina, 50 • 15º andar
 Curitiba PR 80240-210
 Tel: (041) 3342 1600 • Fax: (041) 3244 2200
 vendas@eaglevision.com.br • www.eaglevision.com.br





Powerful Solutions

EagleEyes CCTV

SECURITY SOLUTIONS AND TECHNOLOGIES

Technical Specification EE-LCD15-3DRK

Panel	Cell Type / Glass Surface	TFT LCD / Black Anti-Glare, low reflection coating		
	Aspect Ratio / Size	4 : 3 / 15" viewable diagonal area		
	Active Area / Pixel Pitch	304.13(H) x 228.10(V) mm / 0.297(H) x 0.297(V) mm		
	Native Resolution / Colors	1024(H) x 768(V) / 16.2 Million		
	Brignthess / Contrast	250 cd/m ² (typ) / 500 : 1		
	Response Time	≤ 12 ms		
	Viewing Angle (typical)	H. 130° (- 65° ~ + 65°) , V. 100°(- 55° ~ + 45°)		
	Light Source	CCFL , Long life, 50,000 hrs (typ)		
Input Sources	PC System	Signal	Analog RGB (0.7/1.0 V _{p-p} , 75 ohms)	
		Sync	Separate Sync, Composite Sync, Sync On Green	
		Frequency	F _H : 30 - 82Khz , F _V : 50 -75Hz	
	Audio System	2W Speaker x 2		
Input Terminals	1 x VGA (15 Pin Female D-Sub) , 1 x PC Audio (Stereo Headphone Jack) , 1 x DC Power Plug			
Convenient Features	Auto Calibration , Back Light Adjustment , Plug&Play (VESA DDC/CI, DDC 2B)			
	OSD Multi-Languages , Wall Mount Ready (VESA 75 x 75 mm)			
Power	External AC-to-12VDC power adapter with universal / Auto-Sensing, AC 90 to 260V, 50 / 60 Hz			
Power Consumption	Operation / Power Saving	20 watt , < 2 watt (Support DPMS)		
Operating Condition	Temperature / Humidity	0°C ~ 50°C (32°F ~ 122°F) , 10% ~ 90% (no condensation)		
Storage Condition	Temperature / Humidity	- 20°C ~ 60°C (- 4°F ~ 140°F) , 10% ~ 90% (no condensation)		
Certification	FCC , CE			
Dimensions	Physical	W x H x D = 482.0 x 310.0 x 61.0 mm		
	Carton	W x H x D = 419 x 380 x 142 mm		
Weight	N.W. / G.W.	5.5 Kgs / 6.5 Kgs		
Container Loaded	20ft / 40ft / 40ft HQ	TBD (Sets , By pallet)		
Options	Touch	Video / TV	Enhanced Panel	Others
	Resistive (With glass)	SV + AV	Panel with LED backlight	Digital Signage(Stand alone)
	Capacitive	SV + AV + AV_Looping	High brightness panel	Networking Digital Signage
	SAW	SV + AV + TV	Wide Temperature	Motion Sensor
			Sun Light Readable	Light Ssensor
				Auto-Dimming



Av. República Argentina, 50 • 15° andar
 Curitiba PR 80240-210
 Tel: (041) 3342 1600 • Fax: (041) 3244 2200
 vendas@eaglevision.com.br • www.eaglevision.com.br

